

SERIES 200



CHARACTERISTICS AND PERFORMANCE

Valve Connection	Slip fit w/ band clamps, dual plates, or sheet metal screws
Mounting Orientation	Universal, any orientation or axis
Commissioned Accuracy	±5 % (Pressure independent)
Input Power	24 VAC ±5 %, 50/60 Hz 106 to 116: 30 VA, 212 to 216: 60 VA
Speed of Response	≤ 1 Second
Designed Max APD	0.25 inWC

ENVIRONMENTAL LIMITATIONS

Operating Temperature	-4 °F to 175 °F (-20 °C to 79 °C) 5 to 95 % RH non-condensing
Storage Temperature	-40 °F to 175 °F (-40 °C to 79 °C) 5 to 95 % RH non-condensing

VALVE CONSTRUCTION

Size	Type	Description	Construction			
			Non-Corrosive		Corrosive	
			Valve Body	Damper & Shaft	Valve Body	Damper & Shaft
106 - 112	Single Valve	Single Valve 6", 8", 10", 12"	E-Coated Galvanized Steel	Stainless Steel	Stainless Steel	Stainless Steel
114 - 116	Single Valve	Single Valve 14" & 16"	Aluminum	Stainless Steel	Stainless Steel	Stainless Steel
212 - 216	Dual valve	Dual Valve 2-12", 2-14", 2-16"	Aluminum	Stainless Steel	Stainless Steel	Stainless Steel

VALVE ACTUATION AND ACCESSORIES

Size	Type	Description	Fail Position		Optional Accessories	
			Option 1	Option 2	Band Clamps	Insulation
106 - 112	Single Valve	Single Valve 6", 8", 10", 12"	Fail In Place	Fail Safe	✓	✓
114 - 116	Single Valve	Single Valve 14" & 16"	Fail In Place	Fail Safe	✓	✓
212 - 216	Dual valve	Dual Valve 2-12", 2-14", 2-16"	Fail In Place	Fail Safe	✗	✓

VALVE MODEL INFORMATION

Unit Size	K Factor	Flow Range (CFM)	Flow Range (LPS)
106	450	0-600	0-283
108	775	0-1050	0-495
110	1250	0-1700	0-802
112	2600	0-2600	0-1228
114	2275	0-3200	0-1510
116	2967	0-4200	0-1982
212	3377	0-4700	0-2218
214	4597	0-6400	0-3020
216	6000	0-8400	0-3964

NOMENCLATURE

Series 200-

Size

- 106 - 06"
- 108 - 08"
- 110 - 10"
- 112 - 12"
- 114 - 14"
- 116 - 16"
- 212 - Dual 12"
- 214 - Dual 14"
- 216 - Dual 16"

Environment

- 1-Non Corrosive
- 2-Corrosive

Options

- 0-None
- 1-band clamps
- 2-Insulated w/band clamp
- 3-Insulated

Actuation

- 1-Fail in Place
- 2-Fail Safe *

*Factory default is open, user changeable

SERIES 200

Performance

The Series 200 is an independent air control valve designed for precise, maintenance-free airflow management and seamless integration with third-party control systems. Utilizing CRC's patented CLV air valve technology, it delivers industry-leading performance with exceptionally low pressure drop and a wide operating range of 0–7,800 CFM, maintaining $\pm 5\%$ airflow accuracy across its entire range. Equipped with full network connectivity, the Series 200 ensures reliable and efficient airflow control with streamlined system compatibility.



SERIES 200 OPERATION MODES

- **Variable Volume:** Adjusts and maintains a precise airflow setpoint based on an external analog signal.
- **Constant Volume:** Regulates a fixed, single airflow setpoint for consistent performance.
- **Dual Setpoint:** Switches between two discrete airflow set points, controlled by an external relay signal.

KEY FEATURES

- **Commissioned Accuracy:** Airflow accuracy of less than $\pm 5\%$ with a minimum of 10 to 1 turndown.
- **Energy Efficient:** Low-pressure-drop design supports static pressures as low as 0.25 inches WC, reducing operating costs.
- **Patented Indirect Sensing Technology:** Maintains unobstructed airflow paths, resistant to duct-borne contaminants.
- **Flexible Installation:** No inlet/outlet restrictions, with unrestricted mounting orientation and axis installation options.
- **Advanced Damper Design:** Engineered for precise airflow control and superior damper authority, with the capability for full closure.
- **Long-Term Repeatability:** Delivers consistent performance with no scheduled maintenance required.
- **High-Capacity Airflow Range:** Supports airflow rates from 0 to 7,800 CFM.
- **Durable Construction:** Built for both corrosive and non-corrosive environments, with stainless steel construction and optional protective coatings for extreme conditions.
- **High-Speed Actuation:** Compatible with both Fail-Safe and Fail-In-Place operation modes for rapid response.
- **Multiple Actuation Options:** Configurable for high-speed actuation to meet various control needs.
- **Fail-Safe & Fail-In-Place Modes:** Provides dependable operation under diverse conditions.

SERIES 200

Performance



SERIES 200 APPLICATIONS

The Series 200 is designed to support multiple airflow control applications, including:

- **Variable Volume:** Modulates airflow based on an external control signal.
- **Constant Volume:** Maintains a fixed airflow setpoint.
- **Dual Setpoint:** Switches between two predefined airflow setpoints.

SERIES 200 OPERATING MODES

VARIABLE VOLUME

When set to Variable Volume mode, the Series 200 air valve modulates airflow to maintain a setpoint based on a hard-wired scaled voltage signal, typically provided by a Building Automation System (BAS) controller.

- The input signal can be configured for 0-5VDC, 2-10VDC, or 0-10VDC.
- The corresponding airflow setpoint range is determined by the valve size.
- A purge setpoint can be optionally configured.

CONSTANT VOLUME

When set to Constant Volume mode, the Series 200 air valve maintains a fixed airflow setpoint at all times.

- The setpoint can be adjusted via the touchscreen interface or BACnet®.
- An optional purge setpoint can be configured.

DUAL SETPOINT

In Dual Setpoint mode, the Series 200 air valve regulates airflow to maintain either a primary (Setpoint A) or secondary (Setpoint B) airflow setpoint.

- A hardwired digital input, such as an externally supplied switch, can trigger the transition between setpoints.
- Setpoints can be adjusted via the touchscreen interface or BACnet®.
- An optional purge setpoint can also be configured.

SERIES 200

Performance

SERIES 200 PERFORMANCE DATA

Valve Size	Eng. Units	Optimal Performance Design Range												Max CFM	Valve Size
		±20%	≤15%	≤7%	≤5%	≤3%	≤2%	≤1%	≤1%	≤1%	≤1%	≤1%	≤1%		
106	CFM	0-30	30	40	60	100	120	220	300	380	440	480	540	600	106
108	CFM	0-60	60	80	100	160	200	360	540	680	800	900	980	1050	108
110	CFM	0-80	80	140	170	300	400	640	900	1140	1320	1440	1600	1700	110
112	CFM	0-160	160	200	240	380	560	920	1420	1720	2000	2280	2500	2900	112
114	CFM	0-180	180	240	310	540	800	1200	1720	2100	2420	2700	2960	3100	114
116	CFM	0-210	210	315	420	700	1000	1580	2210	2730	3125	3520	3850	4200	116
212	CFM	0-230	230	350	460	660	1100	1760	2520	3040	3520	3800	4100	4600	212
214	CFM	0-360	360	480	600	1080	1600	2400	3240	4200	4840	5200	5400	6000	214
216	CFM	0-420	420	630	780	1400	2000	3160	4420	5460	6250	6800	7200	7800	216
ΔPS	inWC	≤0.005	≤0.005	≤0.005	≤0.005	0.01	0.02	0.05	0.10	0.15	0.20	0.25	0.30	inWC	ΔPS

SERIES 200 PERFORMANCE CHART

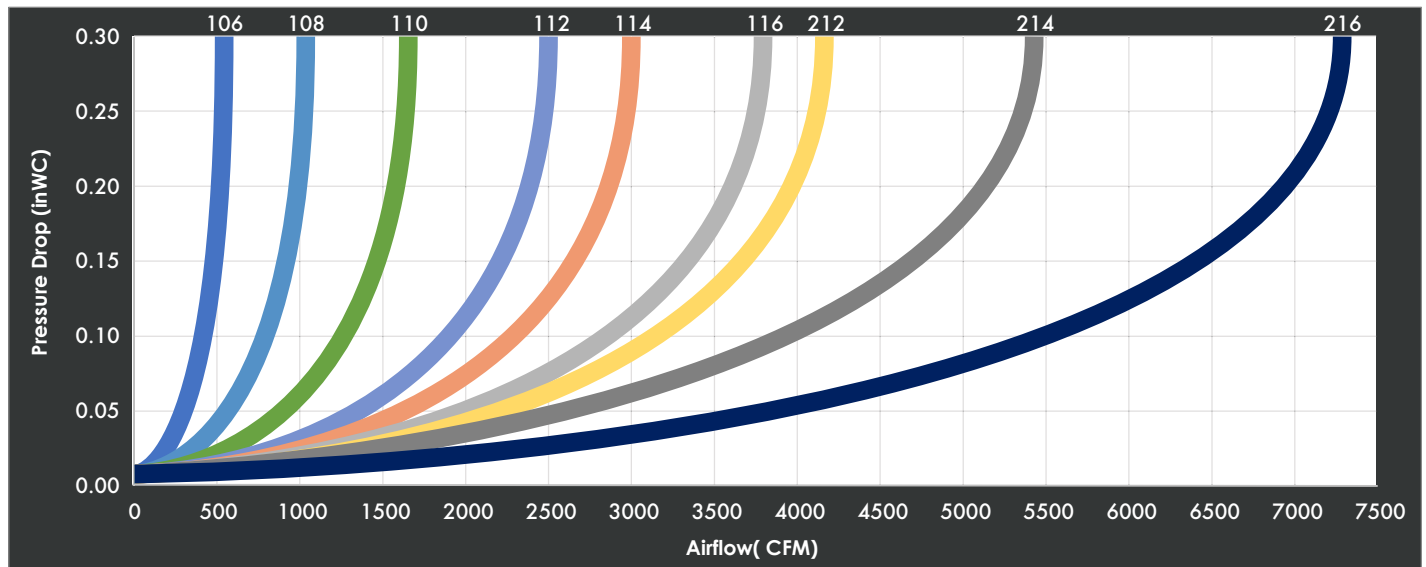

⚠ To achieve optimal energy-efficient performance, choose a valve size that maintains a maximum pressure drop of 0.25" at the design airflow rate.

SERIES 200

Dimensional Data

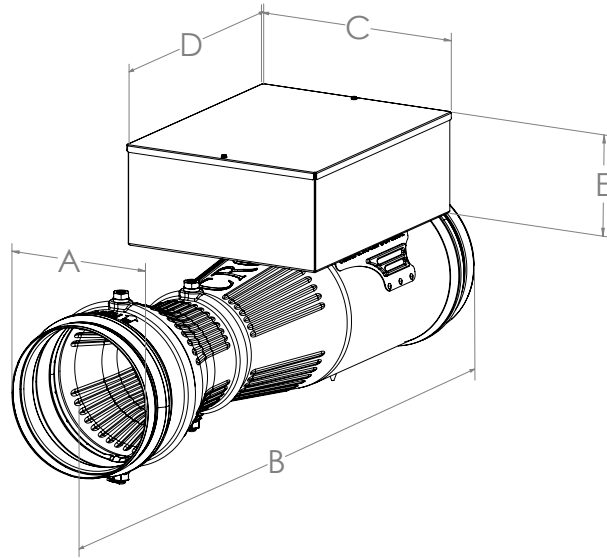

SERIES 200 SINGLE CLV

Valve Size	A	B	C	D	E
	in [mm]	in [mm]	in [mm]	in [mm]	in [mm]
106	5.9 [149]	28.5 [724]*	13.6 [345]	17.1 [435]	6.5 [165]
108	7.9 [200]	34.8 [884]*	13.6 [345]	17.1 [435]	6.5 [165]
110	9.9 [251]	39.3 [998]*	13.6 [345]	17.1 [435]	6.5 [165]
112	11.9 [302]	40.5 [1029]*	13.6 [345]	17.1 [435]	6.5 [165]
114	13.9 [352]	48.0 [1220]	13.6 [345]	17.1 [435]	6.5 [165]
116	15.9 [381]	48.0 [1220]	13.6 [345]	17.1 [435]	6.5 [165]

*Length measurement is taken from gasket to gasket to account for the slip-fit connection.

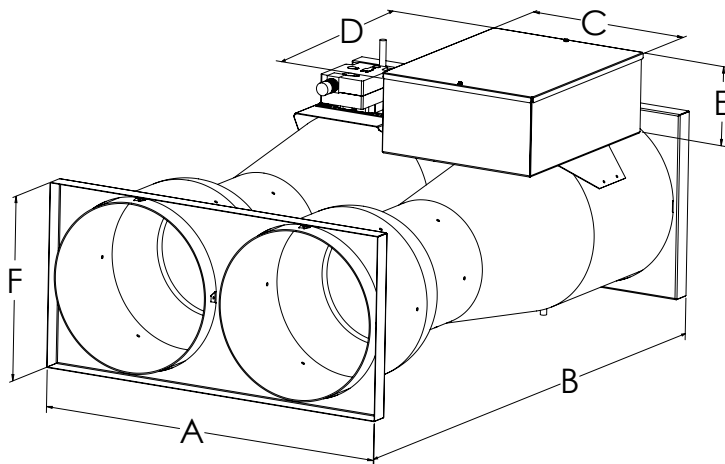

SERIES 200 DUAL CLV

Valve Size	A	B	C	D	E	E
	in [mm]	in [mm]	in [mm]	in [mm]	in [mm]	in [mm]
212	26.0 [660]	48.0 [1220]	13.6 [345]	17.1 [435]	6.5 [165]	13.0 [165]
214	30.0 [762]	48.0 [1220]	13.6 [345]	17.1 [435]	6.5 [165]	15.0 [165]
216	34.0 [864]	48.0 [1220]	13.6 [345]	17.1 [435]	6.5 [165]	17.0 [165]

SERIES 200

Wiring Guide (Variable Volume)

- 1 **BACnet® MS/TP Connection:** Supports communication via BACnet® MS/TP protocol.
- 2 **Field Programming Tool:** Utilizes a CAT6 connector for configuration and programming.
- 3 **Setpoint Input Signal:** Accepts an analog input from a third-party device, providing a linear airflow setpoint based on the Series 200 size and corresponding CFM range (refer to the applicable flow chart).
- 4 **Damper Position Output:** Provides a 0-10V analog output signal indicating damper position, where 0.0V = 100% closed and 10.0V = 100% open.
- 5 **Airflow Output:** Outputs a 0-10VDC linear analog signal representing airflow in CFM, scaled according to the Series 200 size (refer to the Series 200 Airflow Range Chart for details).
- 6 **Isolation Transformer:** 24VAC Isolation transformer supplied by CRC, wired to both board and actuator.
 - ⚠ Customer should land wiring (hot and neutral) at factory installed connectors.
- 7 **Purge Activation Input:** Engages the purge mode when a third-party relay is closed, driving the Series 200 to the designated purge CFM setpoint.
- 8 **Purge Activation Output:** A relay closes when the Series 200 enters purge mode, enabling secondary indication for third-party devices (e.g., local alarm or strobe).
- 9 **Flow Alarm:** A relay activates if the Series 200 airflow fails to maintain the setpoint for more than 60 seconds. This function is only active when the alarm is enabled.

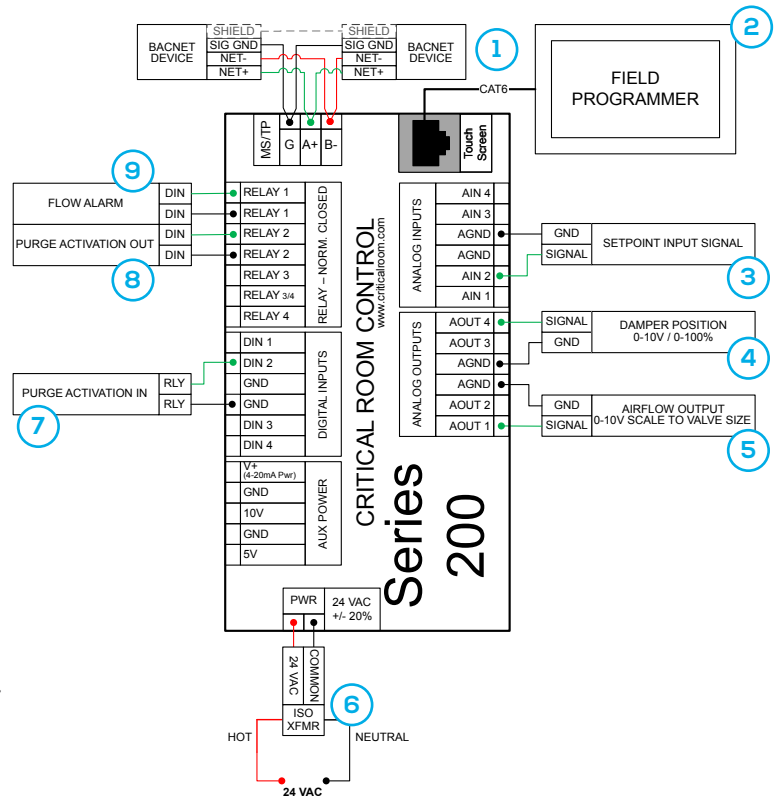

SERIES 200

Wiring Guide (Constant Volume)

- 1 **BACnet® MS/TP Connection:** Supports communication via BACnet MS®/TP protocol.
- 2 **Field Programming Tool:** Utilizes a CAT6 connector for configuration and programming.
- 3 **Damper Position Output:** Provides a 0-10V analog output signal indicating damper position, where 0.0V = closed and 10.0V = 100% open.
- 4 **Airflow Output:** Outputs a 0-10VDC linear analog signal representing airflow in CFM, scaled according to the Series 200 size (refer to the Series 200 Airflow Range Chart for details).
- 5 **Isolation Transformer:** 24VAC Isolation transformer supplied by CRC, wired to both board and actuator.
 - ⚠ Customer should land wiring (hot and neutral) at factory installed connectors.
- 6 **Purge Activation Input:** Engages the purge mode when a third-party relay is closed, driving the Series 200 to the designated purge CFM setpoint.
- 7 **Purge Activation Output:** A relay closes when the Series 200 enters purge mode, enabling secondary indication for third-party devices (e.g., local alarm or strobe).
- 8 **Flow Alarm:** A relay activates if the Series 200 airflow fails to maintain the setpoint for more than 60 seconds. This function is only active when the alarm is enabled.

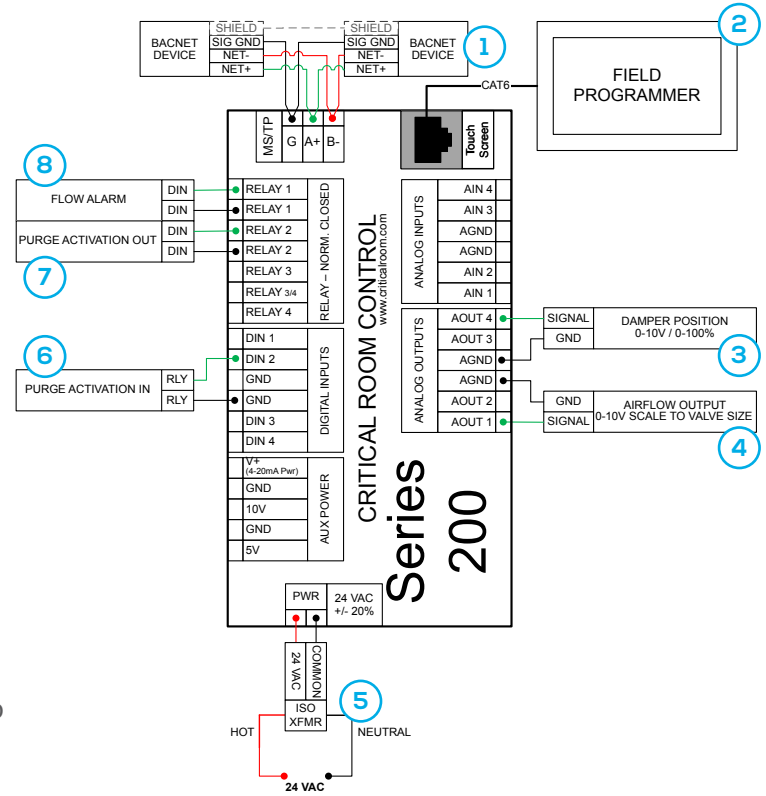

SERIES 200

Wiring Guide (Dual Setpoint)

- 1 **BACnet® MS/TP Connection:** Supports communication via BACnet® MS/TP protocol.
- 2 **Field Programming Tool:** Utilizes a CAT6 connector for configuration and programming.
- 3 **Damper Position Output:** Provides a 0-10V analog output signal indicating damper position, where 0.0V = 100% closed and 10.0V = 100% open.
- 4 **Airflow Output:** Outputs a 0-10VDC linear analog signal representing airflow in CFM, scaled according to the Series 200 size (refer to the Series 200 Airflow Range Chart for details).
- 5 **Isolation Transformer:** 24VAC Isolation transformer supplied by CRC, wired to both board and actuator.
 - ⚠ Customer should land wiring (hot and neutral) at factory installed connectors.
- 6 **Purge Activation Input:** Engages the purge mode when a third-party relay is closed, driving the Series 200 to the designated purge CFM setpoint.
- 7 **Setpoint A/B Selection:** Allows the Series 200 to switch between two distinct CFM setpoints. Controlled by a third-party relay, where Open = Setpoint A and Closed = Setpoint B.
- 8 **Purge Activation Output:** A relay closes when the Series 200 enters purge mode, enabling secondary indication for third-party devices (e.g., local alarm or strobe).
- 9 **Flow Alarm:** A relay activates if the Series 200 airflow fails to maintain the setpoint for more than 60 seconds. This function is only active when the alarm is enabled.

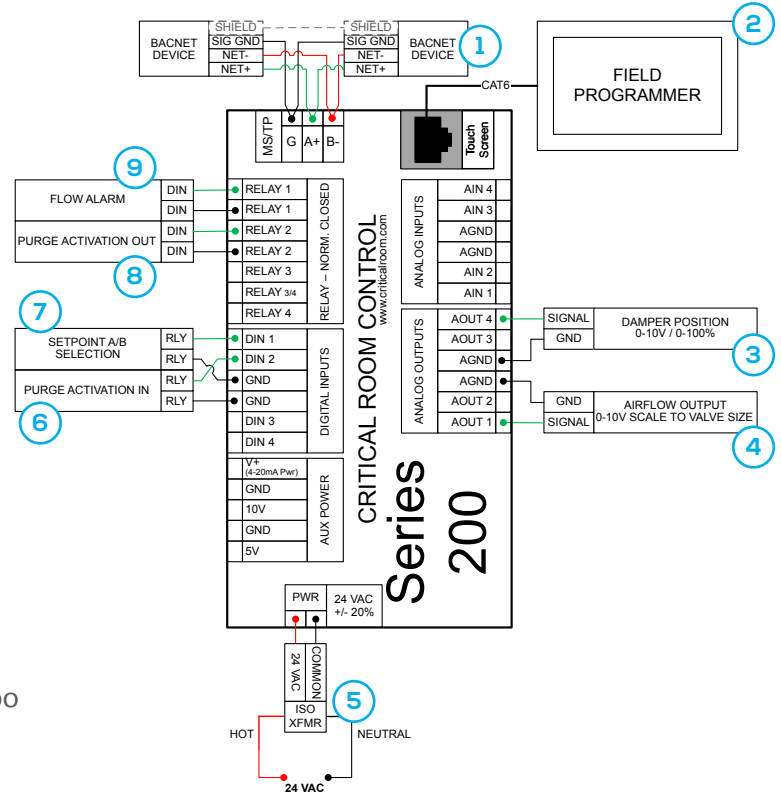

SERIES 200

Optional Accessories

BAND CLAMPS



Top View

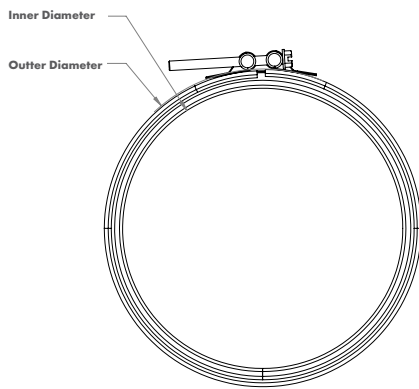

Side View

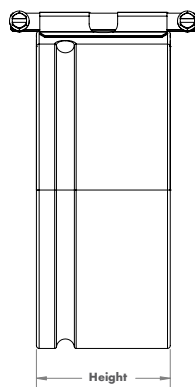

INSULATION



CHARACTERISTICS

Material of Construction	Galvanized Steel
Gasket	UL94 Neoprene
Design	Dual-Bolt
Torque	Not to exceed 40 in-lbs
Band Clamps provided in sets of (2)	

SIZE CHART

Part #	Inner Diameter	Outer Diameter	Height
BC-106	[136.65] 5.38	[159.93] 6.3	[89.33] 3.52
BC-108	[187.45] 7.38	[211.93] 8.34	[89.5] 3.52
BC-110	[238.25] 9.38	[262.73] 10.34	[89.5] 3.52
BC-112	[289.05] 11.38	[313.53] 12.34	[89.5] 3.52
BC-114	[339.85] 13.38	[364.33] 14.34	[89.5] 3.52
BC-116	[390.65] 15.38	[415.13] 16.34	[89.5] 3.52

CHARACTERISTICS

Material of Construction	Closed-cell elastomeric thermal insulation
Gasket	0.25" (6.4 mm)
Design	R-1.0

ENVIRONMENTAL LIMITATIONS

Upper Temperature Limit	220 °F (104 °C)
Lower Temperature Limit	-297 °F (-183 °C)
Flame Spread and Smoke Developed Index	25/50 rated

⚠ Valve insulation is factory installed

Key

[BRACKETS] = MILLIMETERS (mm)

NO BRACKETS = INCHES (in)